

TCO10HRS



❖ Features:

- AlGaAs/GaAs Epi Wafer
- Double heterojunction structure

❖ Typical Applications:

- Lamp
- Display

❖ Outline Dimensions:

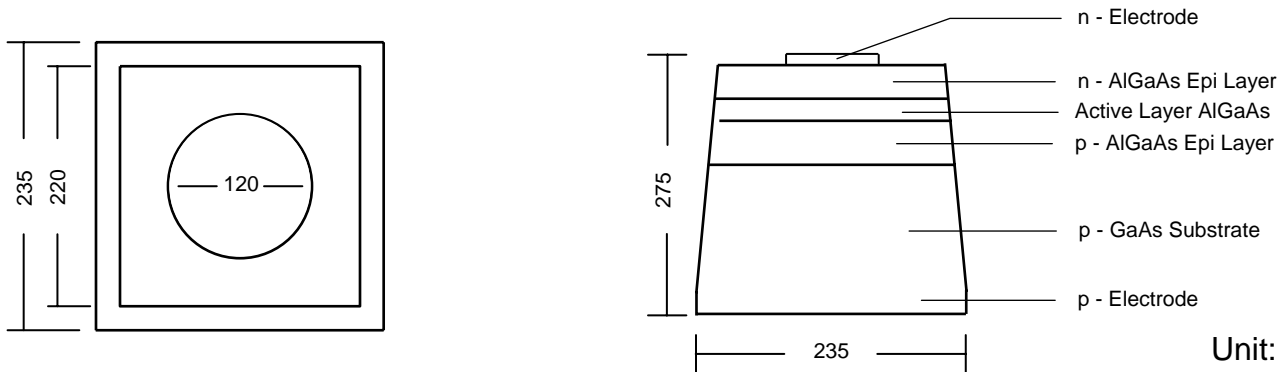

Unit: μm

❖ Physical Structure:

Chip dimensions		Chip size	9.25 mil x 9.25 mil	235 μm x 235 μm
		Thickness	11 mil	275 μm
		Emission area	8.6 mil	220 μm
		Bonding pad	4.7 mil	120 μm
Electrode	Top	N (cathode)	Aluminium (Gold optional)	
	Backside	P (anode)	Gold alloy	

❖ Electro-Optical Characteristics:

Parameter	Symbol	Condition	Min.	Typ.	Max.	Unit
Forward Voltage	V_F	$I_F = 20\text{mA}$	-	1.80	2.00	V
Wavelength	λ_p	$I_F = 20\text{mA}$	-	648	-	nm
	Hue		-	635	-	
Spectral width at half height	$\Delta\lambda$	$I_F = 20\text{mA}$	-	20	-	nm
Reverse Voltage	V_R	$I_R = 10\mu\text{A}$	5.0	-	-	V
Luminous Intensity	I_V	$I_F = 20\text{mA}$	14	-	-	mcd